

# FRAMES

## MOGUL

### Mogul DH

Developed for the typical UK courses, this frame with it's top of the tree Vivid R2C shock provides 7.5" of plush travel.

Ridden, raced and approved during 2011 on the Halo British Downhill Series (as well as Morzine) by Team Identiti riders Pat Campbell-Jenner, Matt Jones and Tom Knight.

With their invaluable feedback we have made a few adjustments and the Identiti Mogul DH frame is now ready to go into production for 2012.

The Mogul provides outstanding value (as always from Identiti).

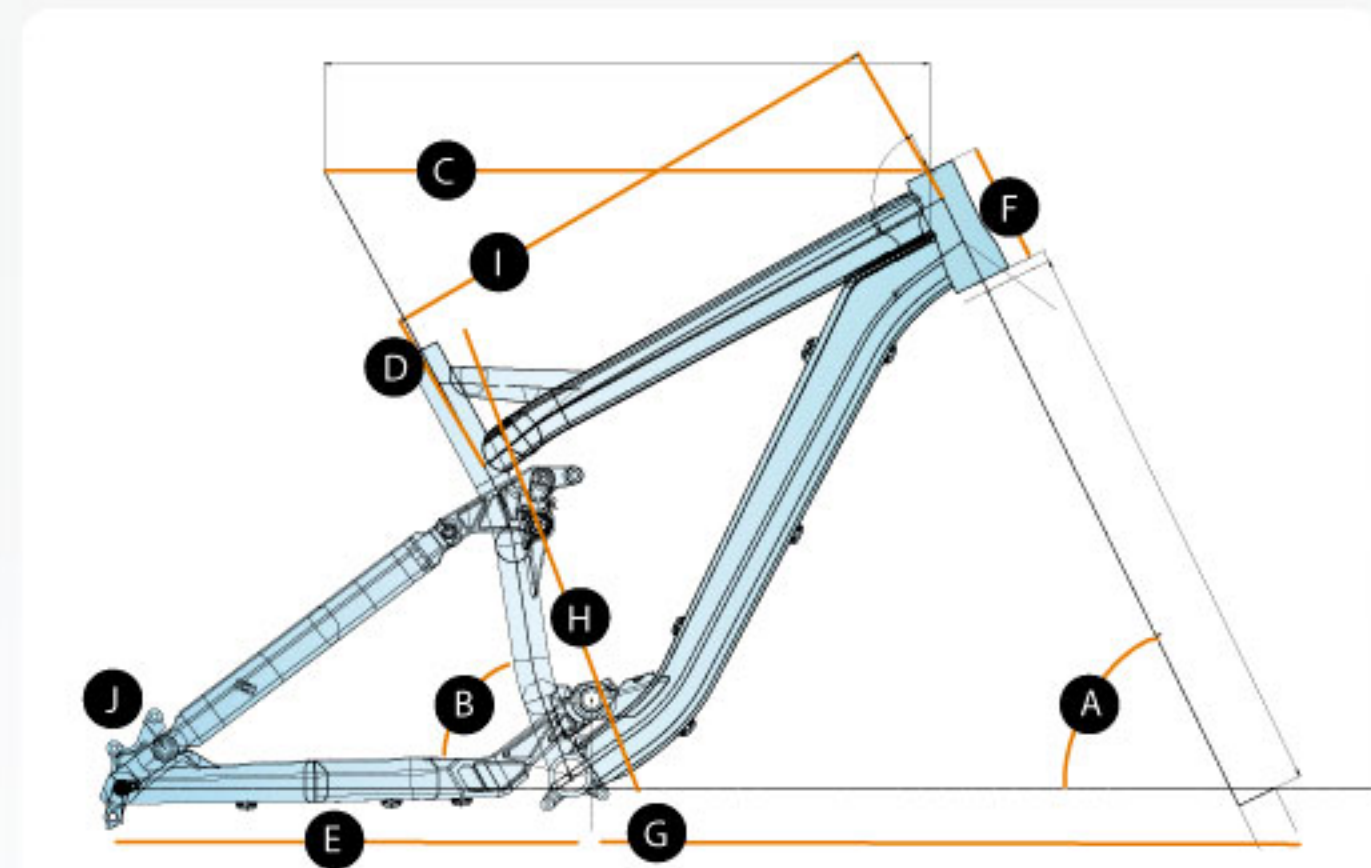

SIZE	SML	MED	LRG
A. Head Angle	64°	64°	64°
B. Seat Angle	68.5°	68.5°	68.5°
C. Effective Top Tube	572	597	662
D. Seat tube Dia	30.9	30.9	30.9
E. Chainstay	443.2	443.2	443.2
F. Head Tube	110	120	130
G. BB Height	12	12	12
H. Seat Tube	432.4	444.9	457.5
I. Top Tube	501.7	523.8	545.3
J. Dropout	150x12	150x12	150x12
.Weight	from 2.9kg	from 2.9kg	from 2.9kg

Measurements are in mm unless indicated otherwise.  
Frame angles are measured static, without rider sag.  
Quoted allowing Fork A to C of 565mm

- 6061 Aluminium
- Tapered Headtube: 1 1/8" - 1.5"
- Weight 2.9kg (6.4lbs) w/out shock.
- BB: 83mm
- ISCG05 Tabs
- Inc. Rock Shox Vivid R2C coil shock.
- Shock Length 222/69mm
- Dropout: 12mm x 150mm e-thru system.
- Tyre: 26" x 2.40"
- Seatclamp: 34.9

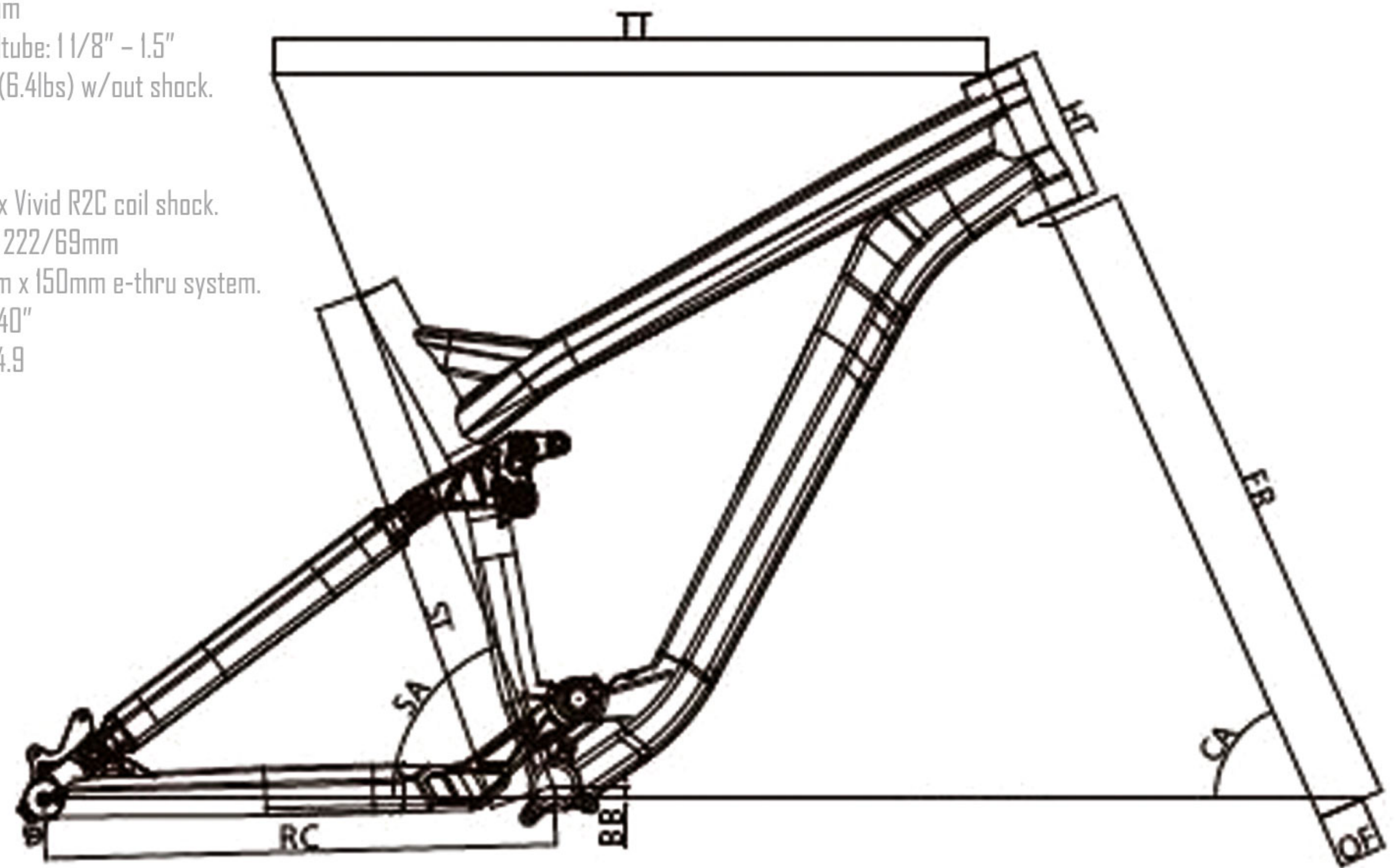

TAG Heuer  
PROFESSIONAL TIMING



www.halobritishdownhillseries.com